

Q10HA-9500R

SURFACE MOUNT 12dB DIRECTIONAL COUPLER

REV 1.1.0

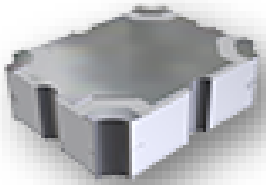

APPLICATIONS

- Signal Splitting/Combining
- Balanced Amplifier Circuit
- I/Q Modulators/Demodulators
- Analog Phase Shifters
- Analog Variable Attenuators
- Microwave Mixers
- Image Reject Mixers
- Integrated Circuits
- And More...

FEATURES

- Excellent RF performance; low insertion loss, tight coupling, low amplitude balance, close phase tracking
- Compact and low profile
- Industry standard sizes and footprint
- Optimized for thermal and RF performance
- Dimensionally stable materials for best CTE match

SPECIFICATIONS

TABLE 1: TYPICAL SPECIFICATIONS*

FREQ (MHz)	POWER (W)	PART NUMBER	INSERTION LOSS (dB)	COUPLING (dB)	DIRECTIVITY (dB)	VSWR	OPERATING TEMP (°C)
7000-12000	20	Q10HA-9500R	0.50	12 ± 1.25	14	1.4	-55 to +95

* Units tested with small signal using Electro-Photonics test board at 25°C. Specifications subject to change without notice.

MECHANICAL OUTLINE

* Dimensions are inches [millimeters].

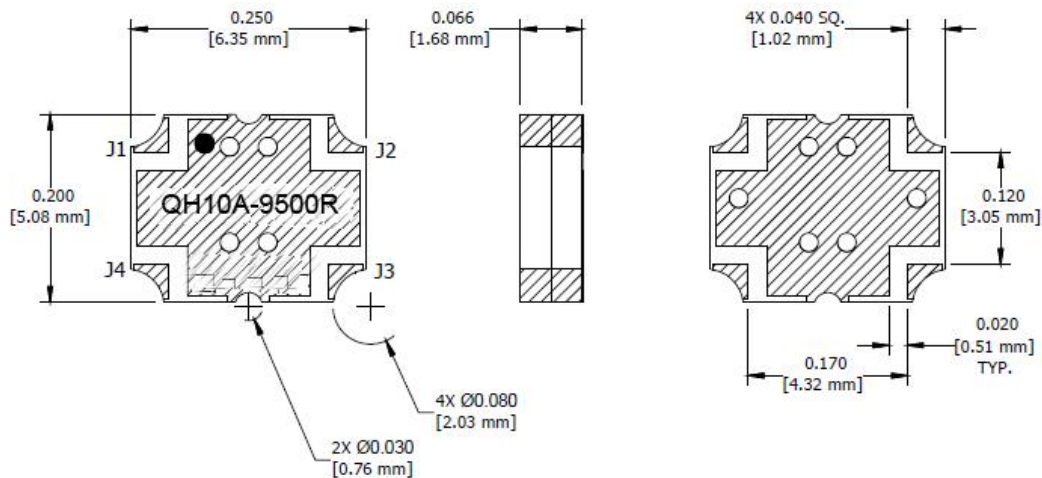

Q10HA-9500R

SURFACE MOUNT 12dB DIRECTIONAL COUPLER

REV 1.1.0

TYPICAL PERFORMANCE

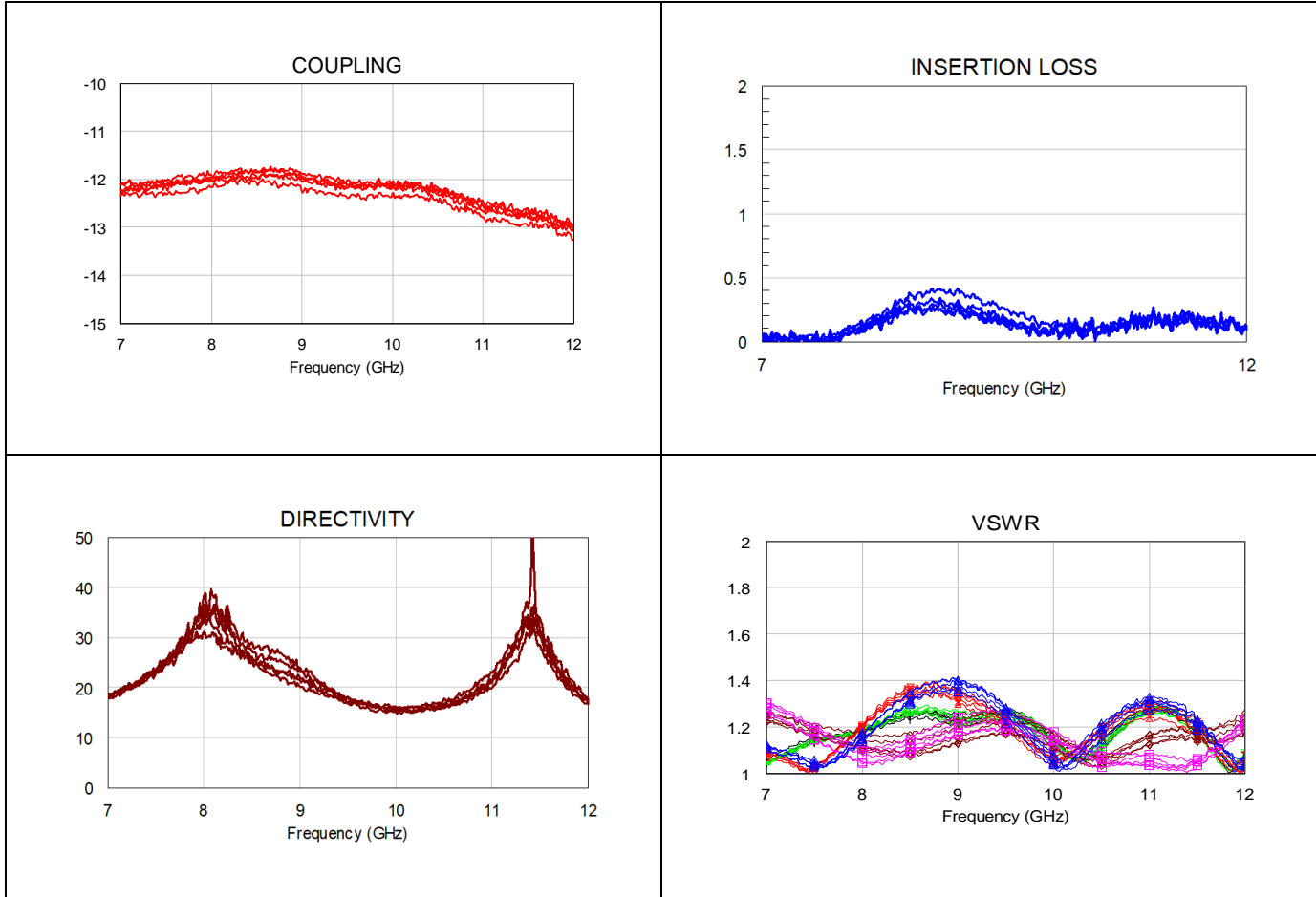

Specifications subject to change without notice

Q10HA-9500R

SURFACE MOUNT 12dB DIRECTIONAL COUPLER

REV 1.1.0

POWER DERATING

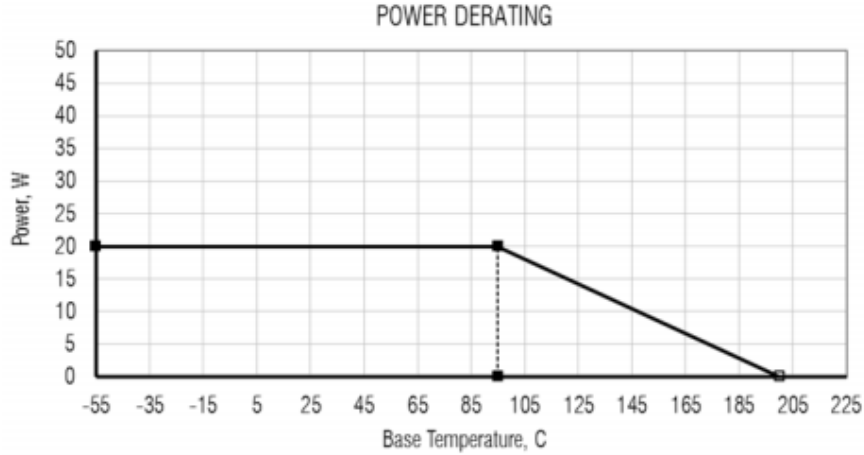

PIN CONFIGURATION

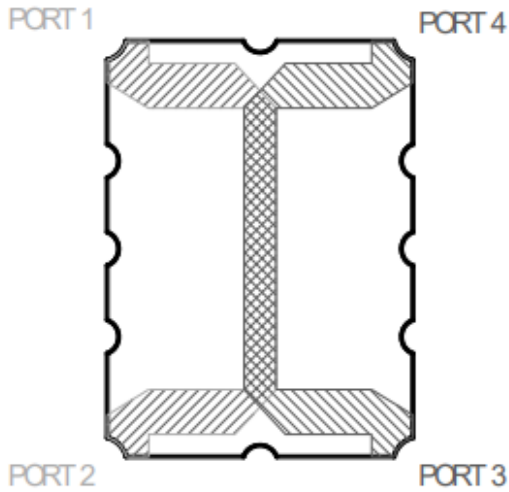

PORT 1	PORT 2	PORT 3	PORT 4
IN	DIRECT	ISOLATED	COUPLED
DIRECT	IN	COUPLED	ISOLATED
ISOLATED	COUPLED	IN	DIRECT
COUPLED	ISOLATED	DIRECT	IN

Q10HA-9500R

SURFACE MOUNT 12dB DIRECTIONAL COUPLER

REV 1.1.0

MOUNTING FOOTPRINT

Electro-Photonics test board is designed using 30 mil RO4350B material. Land pattern design must be taken into consideration when using a different thickness and/or dielectric constant in order to achieve optimal performance.

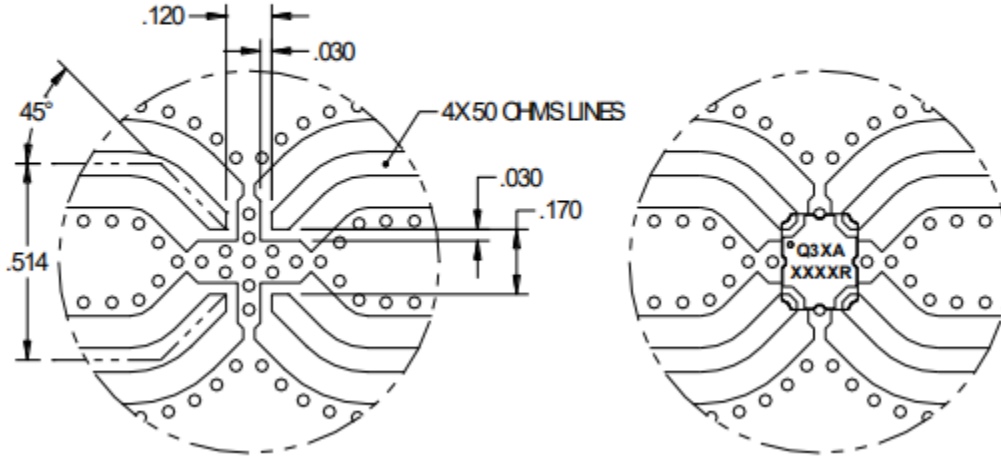

LEAD-FREE SOLDER PROFILE

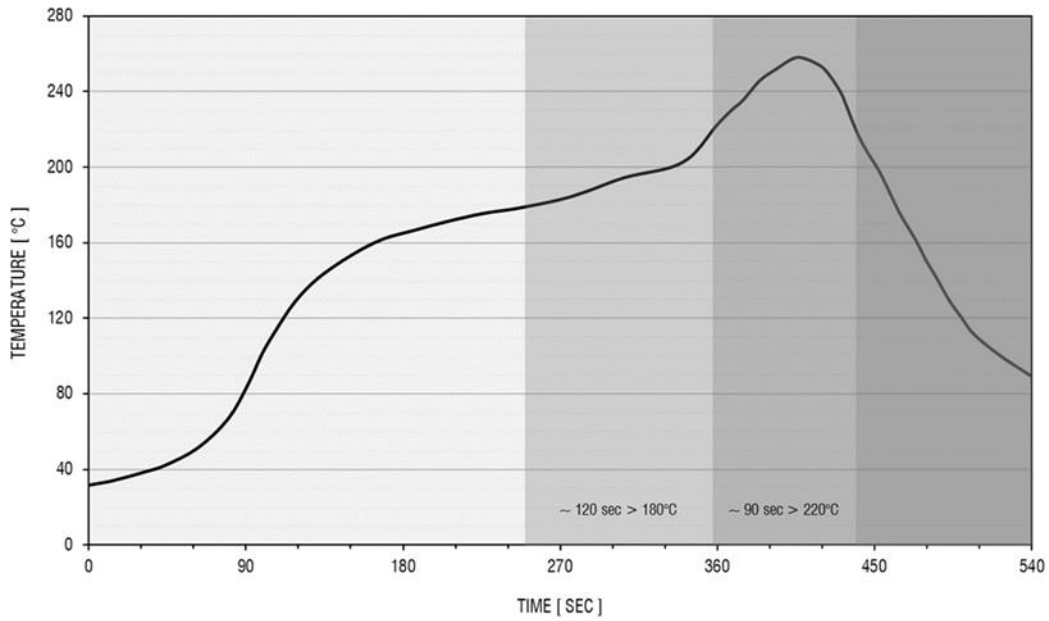

Q10HA-9500R

SURFACE MOUNT 12dB DIRECTIONAL COUPLER

REV 1.1.0

ORDERING INFO

Q 1 0 H A - 9 5 0 0 R -

① ② ③ ④ ⑤

①	②	③	④	⑤
PRODUCT CODE	SIZE	FREQUENCY	PLATING	
12dB DIRECTIONAL COUPLER	A = .250 X .200 B = .560 X .200 G = .560 X .350 D = .650 X .480	MHz	R = IMMERSION TIN	T=Tape & Reel

The Q10HA-9500R is lead free, RoHS compliant product.

